

C14 IEC Inlet - Medical Filter

EMI FILTER OPTIONS

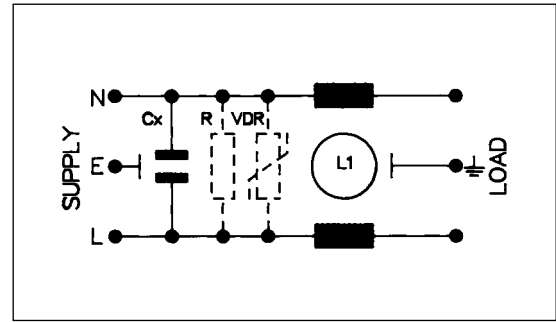

- For Polysnap modules BZV03, BZV04, BZV09, BZV10, BZV17, BZV18, BZH09, BZH10, BZH17, BZH18, BZM27, BZM28
- PX0575 style IEC inlet
- Using PS01/B style filter
- Medical Filter



IEC CONNECTORS

Bxxxx/Bxx x x / xx

Polysnap Part No.	Filter Type	Rating	L/C Circuit	Additional Components	Polysnap Part No.
From Polysnap Selection	B = Medical	01 = 1A 03 = 3A 06 = 6A 10 = 10A	1 = Version 1 2 = Version 2 3 = Version 3	0 = None 1 = Bleed (R) Resistor 2 = Surge (VDR) Protection 3 = "R" plus "VDR"	From Polysnap Selection

Rating	Version	L1	Cx
1 AMP	1	2 x 2.8mH	1 x 15nF
"	2	2 x 10mH	1 x 15nF
"	3	2 x 10mH	1 x 47nF
3 AMP	1	2 x 0.75mH	1 x 15nF
"	2	2 x 1.8mH	1 x 15nF
"	3	2 x 1.8mH	1 x 47nF
6 AMP	1	2 x 0.3mH	1 x 15nF
"	2	2 x 0.7mH	1 x 15nF
"	3	2 x 0.7mH	1 x 47nF
10 AMP	1	2 x 0.17mH	1 x 15nF
"	2	2 x 0.35mH	1 x 15nF
"	3	2 x 0.17mH	1 x 47nF

Part No. Example

BZV04/B0322/04 =

BZV style Polysnap module with PX0575 IEC power inlet, filter rated at 3 amps, L/C circuit version 2 (L1 = 2 x 1.8mH, Cx = 1 x 15nF), without bleed resistor, with surge protection device fitted, 2.8mm tabs and two fuseholders.

Filter Specification

Max. Working Voltage:	250V a.c. 50-400Hz
Earth Leakage Current:	<100µA (typically 5µA, 250V. 50Hz)
Temperature Range:	-25°C to +85°C
Max. Ambient Temp.: (@ Full Load)	40°C (derate linearly to 0A @ 85°C)
Test Voltage:	2700V d.c. 2 secs. Lines to Earth 1100V d.c. 2 secs. Live to Neutral

Approvals:



Attenuation Curves:

See PS01/B filter, page 123

Rating & Version Table

PS00/Bxxxx/xx00 & PS01/Bxxxx/xxxx

Rating	Version	L1	Cx
1 AMP	1	2 x 2.8mH	1 x 15nF
"	2	2 x 10mH	1 x 15nF
"	3	2 x 10mH	1 x 47nF
3 AMP	1	2 x 0.75mH	1 x 15nF
"	2	2 x 1.8mH	1 x 15nF
"	3	2 x 1.8mH	1 x 47nF
6 AMP	1	2 x 0.3mH	1 x 15nF
"	2	2 x 0.7mH	1 x 15nF
"	3	2 x 0.7mH	1 x 47nF
10 AMP	1	2 x 0.17mH	1 x 15nF
"	2	2 x 0.35mH	1 x 15nF
"	3	2 x 0.17mH	1 x 47nF

Version 1

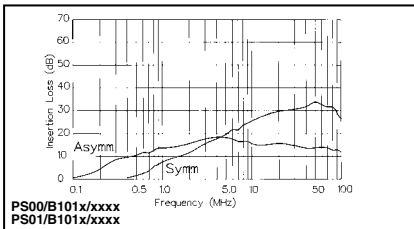
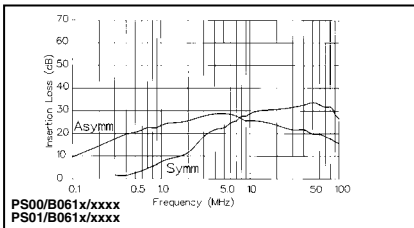
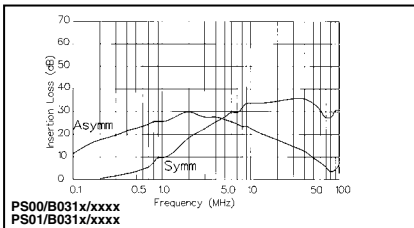
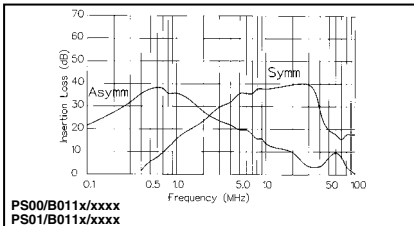

Version 2

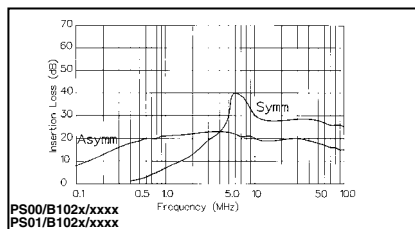
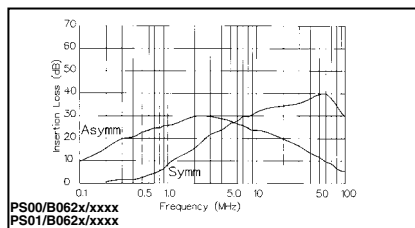
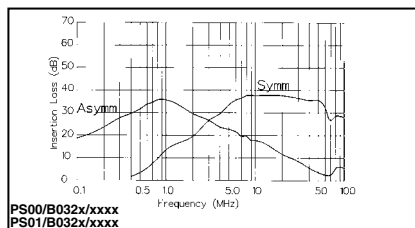
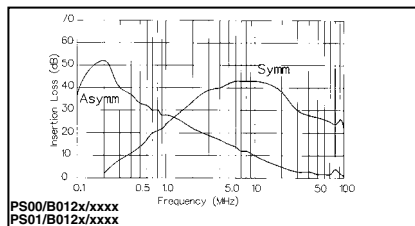

Version 3

