

C14 IEC Fused Inlet - Horizontal

HORIZONTAL MODULE ARRANGEMENT

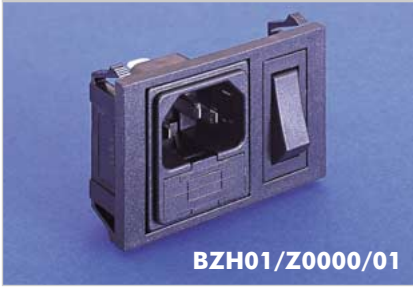

- Fused Inlet with 2.8mm or 6.3mm tabs
- Single Pole Switch Variations
- Filtered Inlet Option
- Options of I/O marked switches

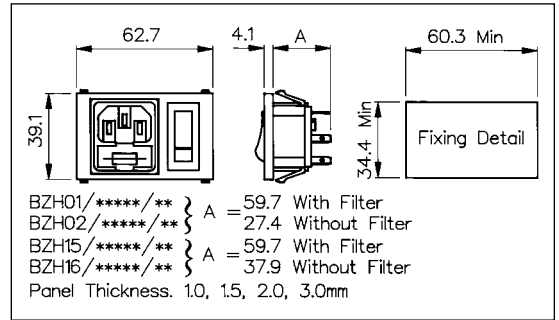

How to Order

BZH xx / xxxxx / xx

Type of Inlet / Outlet	Filtered or Non Filtered Inlet	Combination of Other Components
Single Fused C14 Power Inlet (cold condition), 2.8 or 6.3mm tabs: 01 = PF0011/63 02 = PF0011/28 Twin Fused C14 Power Inlet (cold condition), 2.8 or 6.3mm tabs: 15 = PF0033/63 16 = PF0033/28	Z0000 = Non Filtered Axxxx = Standard Bxxxx = Medical Cxxxx = High Performance Standard (Single Fuse Version only) <div style="border: 1px solid black; padding: 5px; width: fit-content; margin: 10px auto;"> For Filtered inlet use 6th to 9th characters from filter ordering code see pages 115-118. E.g. BZH01/A0620/01 </div>	Single Pole Switch: 01 = S.P. Switch Single Pole Neon Switch: 02 = S.P. Red Neon Switch 08 = S.P. Green Neon Switch Neon Indicator: 03 = Red Neon Indicator Single Pole High Inrush Switch: 46 = S.P. High Inrush Switch Single Pole Switch Marked I/O: 69 = S.P. Switch (I/O) Single Pole Neon Switch Marked (I/O): 71 = S.P. Red Neon Switch (I/O) 74 = S.P. Green Neon Switch (I/O) Single Pole High Inrush Switch Marked (I/O): 98 = S.P. High Inrush Switch (I/O)

Note: For technical details of individual components please see page 92

Components used in Polysnap® and Polyflange Power Inlet Modules

Note: Components are Approved Individually (where applicable). Please see individual component pages for full specifications.

IEC CONNECTORS, FUSEHOLDERS AND VOLTAGE SELECTORS

Type	Description	Rating	Approvals
DX0928	Neon Indicator	110V or 250V a.c./d.c. working	
FX0359	5 x 20mm Fuseholder	Max. rating 10A. 250V See Page 156	
PF0011	C14 Power Inlet with Integral 5 x 20mm Fuseholder	Max. rating 10A. 250V a.c. See Page 67	
PF0033	C14 Power Inlet with Integral twin 5 x 20mm Fuseholder	Max. rating 10A. 250V a.c. See Page 68	
PX0575	C14 Power Inlet, Cold condition	Max. rating 10A. 250V a.c. See Page 63	
PX0595	C16 Power Inlet, Hot Condition	Max. rating 10A. 250V a.c. See Page 69	
PX0695	Sheet F Power Outlet	Max. rating 10A. 250V a.c. See Page 76	
PX0783	Sheet F Shuttered Power Outlet	Max. rating 10A. 250V a.c. See Page 77	
PX0598	C20 Power Inlet	Max. rating 16A, 250V a.c. See Page 79	
VS0001	Voltage Selector marked 120/240V	Max. rating 6.3A. 120/240V a.c. See Page 196	

IEC CONNECTORS

SWITCHES, INDICATORS AND CIRCUIT BREAKERS

No Poles	Illumination	Current Ratings	Circuit	Approvals
Single Pole	Non-illuminated	Max. rating 16A Resistive, 4A Inductive, 250Vac.		
	High Inrush	Max. rating 16A Resistive, 4A Inductive, 250Vac. Inrush current, 150A to IEC65.		
	Illuminated	Max. rating 16A Resistive, 4A Inductive, 250Vac.		
Double Pole	Non-illuminated	Max. rating 16A Resistive, 4A Inductive, 250Vac.		
	High Inrush	Max. rating 16A Resistive, 4A Inductive, 250Vac. Inrush current, 150A to IEC65.		
	Illuminated	Max. rating 16A Resistive, 4A Inductive, 250Vac. 250Vac Neon.		
For Mini Bezel: Single Pole	Non-illuminated	Max. rating 10A Resistive, 4A Inductive, 250Vac.		
	Illuminated	Max. rating 10A Resistive, 4A Inductive, 250Vac. 250Vac Neon.		
Double Pole	Non-illuminated	Max. rating 10A Resistive, 4A Inductive, 250Vac.		
	High Inrush	Max. rating 10A Resistive, 4A Inductive, 250Vac. Inrush current, 85A to EN61058-1.		
	Illuminated	Max. rating 10A Resistive, 4A Inductive, 250Vac. 250Vac Neon.		
Indicator		250Vac neon lamp connected internally to terminals.		
Circuit Breaker	Non-illuminated			
	Illuminated	125Vac and 250Vac Neons.		

RoHS Polysnap and Polyflange range and all components are compliant